

CUSTOMER INFORMATION

CUSTOMER NAME:	
PO NUMBER:	
JOB NUMBER:	
DATE PRINTED:	6/19/2023
PART NUMBER:	4467-BIGFC1-TAX

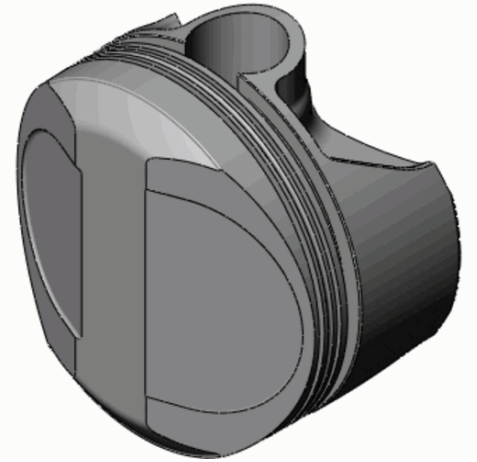

ENGINE SPECIFICATION

MOTOR:	Chrysler	HEAD:	BAE Fat Head	COMP RATIO:		ROD LENGTH:	
MOTOR SIZE:	526	HEAD CC:		BLOCK HEIGHT:		TOP RING RADIAL:	
BORE:	4.4675	INT VALVE DIA:		GASKET THK:		2 nd RING RADIAL:	
STROKE:		EXT VALVE DIA:		DECK CLEARANCE:		OIL RING RADIAL:	

PISTON SPECIFICATION

FORGING#:	TA-X	DISH/DEPTH:		PIN DIAMETER:	1.094
DOME HEIGHT:	.290	CAM PROFILE:	10F6C325L20	PIN FIT TO:	1.0949
DOME/DISH VOL:	19.170	TOP LAND VOL.:	-3.030	PISTON TO CYL CLEAR:	.0065
				PIN LENGTH:	2.850

RING DATA	GROOVE WIDTH		GROOVE DIAMETER	
	INCH	METRIC	INCH	METRIC
TOP RING	.0752	1.9093	4.0550	102.997
2 ND RING	.0640	1.6256	3.9940	101.4476
OIL RING	.1880	4.7752	3.9980	101.5492

VALVE RELIEF	INTAKE		EXHAUST	
	INCH	METRIC	INCH	METRIC
POCKET DEPTH	-.3300	-8.382	-.3150	-8.001
POCKET ANGLE	20.000°		23.000°	
POCKET DIA.	2.7500	69.850	2.2250	56.515

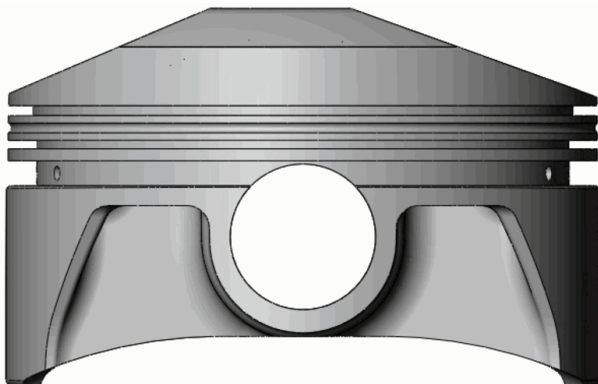

COATINGS:	-
-----------	---

PISTON WEIGHT:	721
----------------	-----

COMPRESSION HEIGHT:	1.425	CENTER OF PIN TO DECK
---------------------	-------	-----------------------

TURN DIA:	4.4610
-----------	--------

GAUGE POINT:	.400	INCHES UP FROM BOTTOM OF SKIRT
--------------	------	--------------------------------