

CUSTOMER INFORMATION

CUSTOMER NAME:

PO NUMBER:

JOB NUMBER: **395571**

DATE PRINTED: **8/21/2020**

PART NUMBER:



ENGINE SPECIFICATION

MOTOR:	Chevrolet Big Block	HEAD:	SR20	COMP RATIO:	13.63:1	ROD LENGTH:	6.385
MOTOR SIZE:	554	HEAD CC:	92	BLOCK HEIGHT:	9.810	TOP RING RADIAL:	.167
BORE:	4.556	INT VALVE DIA:	2.400	GASKET THK:	.051	2 nd RING RADIAL:	.133
STROKE:	4.250	EXT VALVE DIA:	1.800	DECK CLEARANCE:	.000	OIL RING RADIAL:	.147

PISTON SPECIFICATION

FORGING#:	4516	DISH/DEPTH:		PIN DIAMETER:	.990
DOME HEIGHT:	.310	CAM PROFILE:	5C5T17	PIN FIT TO:	.9908
DOME/DISH VOL:	16.060	TOP LAND VOL.:	-1.990	PISTON TO CYL CLEAR:	.0045
				PIN LENGTH:	2.930

RING DATA	GROOVE WIDTH		GROOVE DIAMETER	
	INCH	METRIC	INCH	METRIC
TOP RING	.0438	1.1125	4.1670	105.8418
2 ND RING	.0440	1.1176	4.2350	107.569
OIL RING	.1490	3.7846	4.1770	106.0958

VALVE RELIEF	INTAKE		EXHAUST	
	INCH	METRIC	INCH	METRIC
POCKET DEPTH	-.4100	-10.414	-.0200	-.508
POCKET ANGLE	20.000°		14.000°	
POCKET DIA.	2.5250	64.135	2.0000	50.800

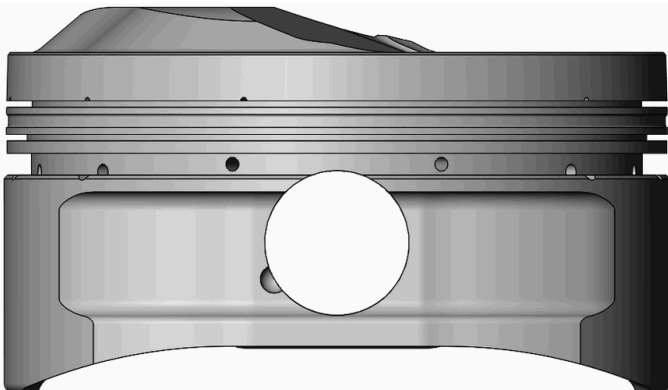

COATINGS:	-
-----------	---

PISTON WEIGHT:	615
----------------	------------

COMPRESSION HEIGHT:	1.300	CENTER OF PIN TO DECK
---------------------	--------------	-----------------------

TURN DIA:	4.5515
-----------	---------------

GAUGE POINT:	.500	INCHES UP FROM BOTTOM OF SKIRT
--------------	-------------	--------------------------------